

RoHS 客户图

目錄 MAPX A0	變更內容 MODIFICATION NEW	日期 DATE 09-10-20
------------------	-----------------------------	------------------------

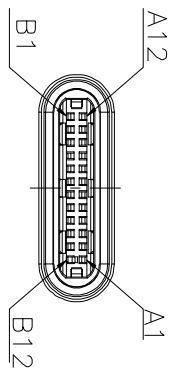
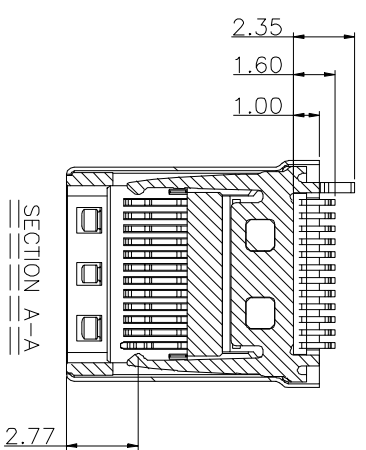
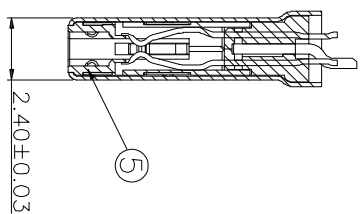
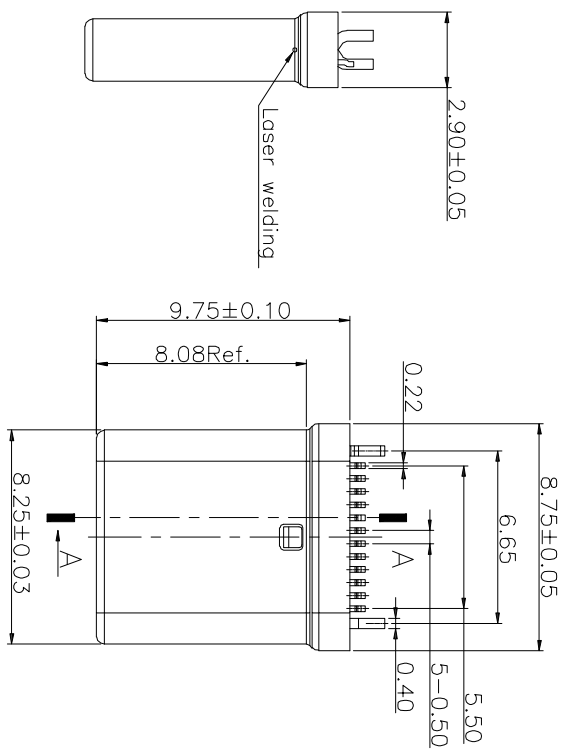
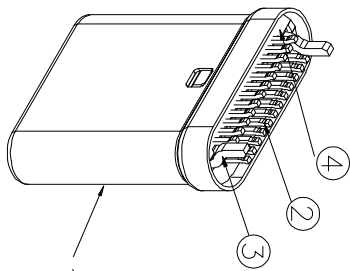
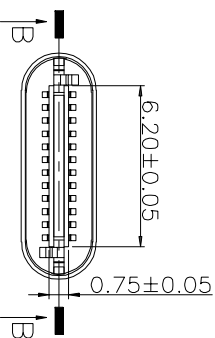

NOTE :
TC02ME016SX01NA

1. Selective Plating
 S1:5u" Gold In Contact Area
 100u" Tin In Tail Area
 S2:0.8u" Gold In Contact Area
 100u" Tin In Tail Area
 S3:10u" Gold In Contact Area
 100u" Tin In Tail Area
 S4:15u" Gold In Contact Area
 100u" Tin In Tail Area
 S5:30u" Gold In Contact Area
 100u" Tin In Tail Area

7					
6					
5	Housing	HIGH TEMP	WHITE	UL 94V-0	
4	Moding	HIGH TEMP	BLACK	UL 94V-0	
3	Latch	STAINLESS STEEL	—	SN Plated	
2	Terminal	COPPER ALLOY	—	Gold Plated	
1	Shell	STAINLESS STEEL	—	Ni Plated	
NO.	DESCRIPTION	MATERIAL	COLOR	REMARK	

产品图

东莞市颖鑫电子科技有限公司

公差一览表 TOLERANCE UNLESS OTHERWISE SPECIFIED		单位 UNITS		制图 DRAWING		产品料号 PRODUCT PART NO.	
X	±0.30	X	±5°	王冠	XFLX007-UCAM002-X		
X	±0.25	X	±2°	雷永健		TYPE C公头2P不带板(华为款)	
.XX	±0.30	.XX	±1°	雷永健			
.XXX	±0.15	.XXX	±0.5°				
日期 DATE		比例 SCALE		审核 CHECK		角法 VIEW	
2009/10/20		1:1		雷永健		版本 VER	
						A0	